



### Features

- 1/3" High Sensitivity CCD
- High Resolution : 550 TV Lines
- Built in IR LED and Sensor
- Built in DC Iris Vari-focal Lens (f=3.8~9.5mm)
- Day&Night (ICR), 2x Digital Zoom (On/Off)
- Digital Slow Shutter (On/Off)
- SDNR (Super Digital Noise Reduction)
- Min. Illumination : 0.00 Lux (IR LED On)
- Auto White Balance
- AGC, BLC, Flickerless (On/Off)
- Extra Video Out Port for Installer
- 3-Axis Movement for Free Lens Rotation
- Dome Size : 100mm



### INSIDE VIEW



### DIMENSIONS

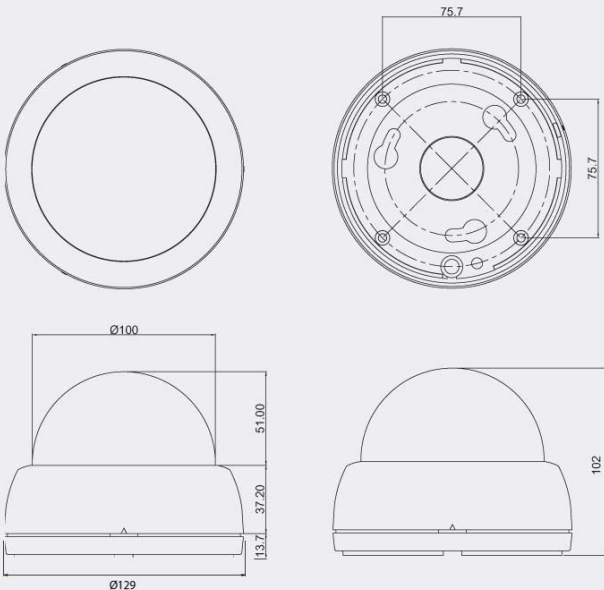

### SPECIFICATIONS

Model	D2815NVR
Signal System	NTSC
Scanning System	2:1 Interlace
Scanning Frequency (H)	15,734 KHz
Scanning Frequency (V)	59.94 Hz
Image Sensor	1/3" High Sensitivity CCD
Total Pixels	811(H) x 508(V) 410K
Total / Effective Pixels	768(H) x 494(V) 380K
Horizontal Resolution	550 TV Lines
Video Output	1.0V p-p (75Ω, Composite)
S/N Ratio	More than 50dB(AGC Off)
Lens	DC Iris Vari-focal Lens (f=3.8~9.5mm)
Digital Zoom Ratio	2x (On/Off, Dip Switch)
Min.Illumination	Day (0.3 Lux), Night (0.00Lux, IR LED On)
IR LED and Sensor	IR LED (850nm, 30°) 20EA, Sensor 1EA
IR LED Visible Range	Max. 20m
Day&Night (ICR)	On/Off (Dip Switch)
SDNR	Built-in
DSS	On/Off (Dip Switch)
White Balance	Auto
AGC,BLC,Flickerless	On/Off (Dip Switch)
Shutter Speed	1/60~1/120,000 Sec.
Supplied Voltage	24VAC or 12VDC Dual Voltage
Dimensions(ØxH)	100.0 x 102.0 mm
Weight	Approx. 360g